



**MS IMU
3025**

Product Specification & User Guide

Document Number: DOC00713

Document Revision: N

Product Model Number: MS-IMU3025

Product Part Number: MP00075

MEMSENSE.COM

888.668.8743

TABLE OF CONTENTS

1.0 Overview	1
2.0 Specifications	1
2.1 Accelerometer Specifications	1
2.2 Gyroscope Specifications	3
2.3 Magnetometer Specifications	4
2.4 IMU System Specifications	4
3.0 Mechanical	8
3.1 Dimensions	8
3.2 Coordinate System	9
4.0 Communications	10
4.1 Default Settings	10
4.2 Hardware Interface	10
4.2.1 Time of Validity Output – Internal Sample Rate	11
4.2.2 External Trigger Input	11
4.2.3 1 Pulse Per Second Input	11
4.3 Internal Sample Rate	12
4.4 Communication Interface Protocol	12
4.4.1 IMU Sample Rate Configure 0x0204	14
4.4.2 Configure Filter 0x0203	14
4.4.3 Select Sensors 0x0205	15
4.4.4 Config Accel Range 0x0207	16
4.4.5 Config Gyro Range 0x0208	16
5.0 RoHS Compliance	17
5.1 RoHS Compliance Statement	17
6.0 Options	18
6.1 Part Numbering	18
6.2 IMU Accessories	18
6.3 IMU Development Kit	18
6.4 IMU Evaluation Kit	19

1.0 OVERVIEW

The MS-IMU3025 MEMS Inertial Measurement Unit delivers standout inertial performance in an ultra-compact package. The tactical-grade gyro bias instability and sub 7 micro-g accelerometer bias instability supply ample inertial performance to support a wide range of applications from inertial navigation and control to precision platform stabilization. User configurable options allow the IMU to be tuned to your application with configurable bandwidth, sample rate, gyro ranges, accel ranges, 1 PPS input and other measurement parameters. The accelerometer dynamic range configurability spans a range from $\pm 2g$ up to $\pm 40g$ that enables applications from land navigation to catapult launched drone systems. The IMU provides all these features in a package that only measures 1.1 x 1.1 x 0.465 inches

with a mass of only 17.9 grams. The MS-IMU3025's combination of inertial performance, size, and configurability surpasses all IMUs in the market.



2.0 SPECIFICATIONS

2.1 Accelerometer Specifications

Table 1 – Accelerometer Specifications

ACCELEROMETER	$\pm 2g$	$\pm 4g$	$\pm 8g$	$\pm 20g$	$\pm 40g$	UNITS	NOTES
Dynamic Range	± 2	± 4	± 8	± 20	± 40	g	Min, Note 1
Bias Instability	2.6	2.6	2.6	12.3	12.3	μg	Mean XY
	0.7	0.7	0.7	1.7	1.7		1σ XY
	6.7	6.7	6.7	21.2	21.2		Mean Z
	1.1	1.1	1.1	4.1	4.1		1σ Z
Bias Offset	± 395	± 395	± 395	± 1569	± 1569	μg	Mean XY
	± 225	± 225	± 225	± 836	± 836		1σ XY
	± 2000	± 2000	± 2000	± 5000	± 5000		Max XY, Note 2
	± 446	± 446	± 446	± 1637	± 1637		Mean Z
	± 303	± 303	± 303	± 982	± 982		1σ Z
	± 3000	± 3000	± 3000	± 6000	± 6000		Max Z, Note 2
Bias Temperature Error	472	459	475	867	858	μg	Mean XY, Note3
	244	270	253	539	538		1σ XY
	2950	1993	1771	3582	3543		Mean Z, Note3
	587	566	652	1260	1252		1σ Z
Scale Factor Error	± 128	± 133	± 132	± 134	± 137	ppm	Mean X
	± 23	± 24	± 24	± 41	± 39		1σ X
	± 185	± 190	± 195	± 250	± 250		Max X, Note 2
	± 141	± 146	± 143	± 116	± 119		Mean Y
	± 26	± 27	± 26	± 41	± 40		1σ Y
	± 215	± 215	± 215	± 225	± 240		Max Y, Note 2
	± 378	± 391	± 372	± 300	± 308		Mean Z
	± 269	± 304	± 246	± 180	± 187		1σ Z
± 1230	± 1270	± 1200	± 850	± 875		Max Z, Note 2	
Scale Factor Temperature Error	191	199	192	1283	1293	ppm	Mean X, Note3
	47	52	54	939	955		1σ X
	401	430	432	434	435		Mean Y, Note3
	191	177	189	167	189		1σ Y
	2732	1703	1593	2751	2779		Mean Z, Note3
	562	544	509	740	766		1σ Z

Information provided herein is considered accurate however is not guaranteed. Memsense reserves the right to change specifications at any time, without notice.

ACCELEROMETER (cont.)	± 2g	± 4g	± 8g	± 20g	± 40g	UNITS	NOTES
Nonlinearity	± 583	± 2609	± 10435	± 2572	± 10301	ppm of FS	Mean X
	± 30	± 66	± 221	± 54	± 145		1σ X
	± 583	± 2609	± 10435	± 2572	± 10301		Mean Y
	± 30	± 66	± 221	± 54	± 145		1σ Y
	± 583	± 2609	± 10435	± 2572	± 10301		Mean Z
	± 30	± 66	± 221	± 54	± 145		1σ Z
Velocity Random Walk	0.0071	0.0071	0.0071	0.0368	0.0368	m/s/h ^{-1/2}	Mean XY
	0.0002	0.0002	0.0002	0.0037	0.0037		1σ XY
	0.0098	0.0098	0.0098	0.0318	0.0318		Mean Z
	0.0003	0.0003	0.0003	0.0008	0.0008		1σ Z
Noise Density	14.8	17.3	17.2	87.9	87.8	μg/Hz ^{-1/2}	Mean X
	0.7	0.9	0.8	2.5	2.5		1σ X
	27.0	28.5	28.5	110.0	110.0		Max X, Note 2
	14.6	17.0	17.0	89.9	89.6		Mean Y
	0.7	0.7	0.7	2.4	2.6		1σ Y
	27.0	28.5	28.5	110	110		Max Y, Note 2
	21.9	23.7	23.3	77.2	77.3		Mean Z
	1.4	1.3	1.2	2.1	2.4		1σ Z
27.0	28.5	28.5	110	110	Max Z, Note 2		
Bandwidth	50	50	50	50	50	Hz	-3dB point, Note 4

Note 1: Dynamic ranges are user configurable via software see Section 4.4.4 for details.

Note 2: Maximum listed is a pass/fail limit in production testing.

Note 3: Error over the operating temperature environment with temperature gradients at or below ±1°C per minute.

Note 4: Bandwidth is user configurable via software, see Section 4.4.2 for details.

2.2 Gyroscope Specifications

Table 2 – Gyroscope Specifications

GYROSCOPE	± 75	± 200	± 480	± 960	± 1920	UNITS	NOTES
Input Range	± 75	± 200	± 480	± 960	± 1920	°/s	Min, Note 1
Bias Instability	0.62	0.62	0.62	0.62	0.62	°/h	Mean X
	0.11	0.11	0.11	0.11	0.11		1σ X
	0.56	0.56	0.56	0.56	0.56		Mean Y
	0.07	0.07	0.07	0.07	0.07		1σ Y
	0.80	0.80	0.80	0.80	0.80		Mean Z
	0.10	0.10	0.10	0.10	0.10		1σ Z
Bias Offset	14.69	14.71	14.66	14.83	14.92	°/h	Mean X
	12.09	12.30	12.14	12.00	12.20		1σ X
	100	100	100	100	150		Max X , Note 2
	18.88	18.93	18.82	19.05	19.24		Mean Y
	15.67	15.70	15.62	15.74	15.77		1σ Y
	100	100	100	100	150		Max Y , Note 2
	11.79	11.83	11.63	11.91	12.02		Mean Z
	8.79	8.79	8.77	8.83	8.93		1σ Z
100	100	100	100	150	Max Z , Note 2		
Bias Temperature Error	57.0	57.0	57.0	57.0	57.0	°/h	Mean, Note 3
	12.8	12.8	12.8	12.8	12.8		1σ
Bias G-Sensitivity	2.30	2.30	2.30	2.30	2.30	°/h/g	Mean
	2.03	2.03	2.03	2.03	2.03		1σ
Bias Vibration Rectification	0.191	0.191	0.191	0.191	0.191	°/h/g _{rms} ²	Mean
	0.197	0.197	0.197	0.197	0.197		1σ
Scale Factor Error	± 1095	± 1109	± 1076	± 1096	± 1049	ppm	Mean X
	± 520	± 518	± 508	± 515	± 612		1σ X
	± 2650	± 2650	± 2600	± 2650	± 2950		Max X , Note 2
	± 897	± 926	± 894	± 936	± 951		Mean Y
	± 465	± 469	± 463	± 471	± 503		1σ Y
	± 2300	± 2350	± 2300	± 2350	± 2450		Max Y , Note 2
	± 1128	± 1145	± 1127	± 1148	± 1120		Mean Z
	± 502	± 518	± 504	± 507	± 501		1σ Z
± 2800	± 2900	± 2900	± 2800	± 2800	Max Z , Note 2		
Scale Factor Temperature Error	2402	2422	2321	2400	2385	ppm	Mean X, Note 3
	235	230	277	245	249		1σ X
	2034	2051	1992	2034	1922		Mean Y, Note 3
	264	263	269	288	280		1σ Y
	1795	1758	1713	1730	1635		Mean Z, Note 3
	154	170	173	175	187		1σ Z
Nonlinearity	± 32	± 24	± 24	± 31	± 90	ppm of FS	Mean X
	± 8	± 10	± 9	± 13	± 42		1σ X
	± 28	± 20	± 20	± 24	± 54		Mean Y
	± 7	± 8	± 6	± 10	± 23		1σ Y
	± 30	± 26	± 23	± 24	± 84		Mean Z
	± 6	± 15	± 8	± 10	± 50		1σ Z
Angle Random Walk	0.163	0.163	0.163	0.163	0.163	°/h ^{-1/2}	Mean X
	0.030	0.030	0.030	0.030	0.030		1σ X
	0.155	0.155	0.155	0.155	0.155		Mean Y
	0.031	0.031	0.031	0.031	0.031		1σ Y
	0.124	0.124	0.124	0.124	0.124		Mean Z
	0.005	0.005	0.005	0.005	0.005		1σ Z

GYROSCOPE (cont.)	± 75	± 200	± 480	± 960	± 1920	UNITS	NOTES
Noise Density	0.0044	0.0044	0.0044	0.0044	0.0044	°/s /Hz ^{-1/2}	Mean X
	<i>0.0004</i>	<i>0.0004</i>	<i>0.0004</i>	<i>0.0004</i>	<i>0.0004</i>		1σ X
	0.0058	0.0058	0.0058	0.0058	0.0058		Max X, Note 2
	0.0041	0.0041	0.0041	0.0042	0.0042		Mean Y
	<i>0.0004</i>	<i>0.0004</i>	<i>0.0004</i>	<i>0.0004</i>	<i>0.0004</i>		1σ Y
	0.0058	0.0058	0.0058	0.0058	0.0058		Max Y, Note 2
	0.0036	0.0036	0.0036	0.0037	0.0037		Mean Z
<i>0.0002</i>	<i>0.0002</i>	<i>0.0002</i>	<i>0.0002</i>	<i>0.0002</i>	1σ Z		
0.0042	0.0042	0.0042	0.0042	0.0042	Max Z, Note 2		
Vibration Noise Coefficient	0.00281	0.00281	0.00281	0.00281	0.00281	°/s/g _{rms} ²	Mean
	0.00237	0.00237	0.00237	0.00237	0.00237		1σ
Bandwidth	50	50	50	50	50	Hz	-3dB point, Note 4

Note 1: Dynamic ranges are user configurable see Section 4.4.5 for details.

Note 2: Maximum listed is a pass/fail limit in production testing.

Note 3: Error over the operating temperature environment with temperature gradients at or below ±1°C per minute.

Note 4: Bandwidth is defined by the software configurable filter cutoff, see Section 4.4.2 for details.

2.3 Magnetometer Specifications

Table 3 – Magnetometer Specifications

MAGNETOMETER		UNITS	NOTES
Dynamic Range	± 1.9	gauss	Min
Offset	± 0.015	gauss	Mean
	± 0.0085		Max, Note 1
Noise Density	80	µgauss /Hz ^{-1/2}	Mean
Bandwidth	50	Hz	-3dB point, Note 2

Note 1: Maximum listed is a pass/fail limit in production testing.

Note 2: Bandwidth is defined by the software configurable filter cutoff, see Section 4.4.2 for details.

2.4 IMU System Specifications

Table 4 – IMU System Specifications

DEVICE TEMPERATURE		UNITS	NOTES
Temperature Error	± 1.5	°C	Max
1 PULSE PER SECOND INPUT			
Voltage Low Level Input	0.9	V	Max
Voltage High Level Input	2.1	V	Min
Trigger Edge	Rising		
EXTERNAL TRIGGER INPUT			
Voltage Low Level Input	0.9	V	Max
Voltage High Level Input	2.1	V	Min
Pulse Width	1.0	µs	Min
TIME OF VALIDITY OUTPUT			
Voltage Low Level Output	0.4	V	Max
Voltage High Level Output	2.6	V	Min
Rise and Fall Time	30	ns	Max
Sample Rate Mean Error	± 10	ppb	
Mean Sample Rate Jitter	± 500	ppb	

PHYSICAL		UNITS	NOTES
Dimensions	1.1 × 1.1 × 0.465	in.	(L x W x H)
Mass	17.9, (18.9)	grams	Typical, (Maximum)
OPERATIONAL REQUIREMENTS		UNITS	NOTES
Supply Voltage	5.0 to 30.0	VDC	
Supply Voltage Startup Slew Rate	50	V/s	Min
Supply Power	0.85	W	Mean, 5V Supply
Operating Temperature	-40 to 85	°C	
Interface Connector	Harwin Gecko G125-MS11005L		10 pin
Mating Connector	Harwin Gecko G125-2041096L0		10 pin
ABSOLUTE MAXIMUM RATINGS		UNITS	NOTES
	NOTE 1		
Acceleration Powered	800	g	0.5 ms any axis
Supply Voltage	-0.3 (min) to 36.0 (max)	VDC	
Storage Temperature	-55 to 85	°C	

Note 1: Absolute Maximum Ratings list device survivability specifications and are non-operational.

MS-IMU3025 Power Consumption vs. Supply Voltage

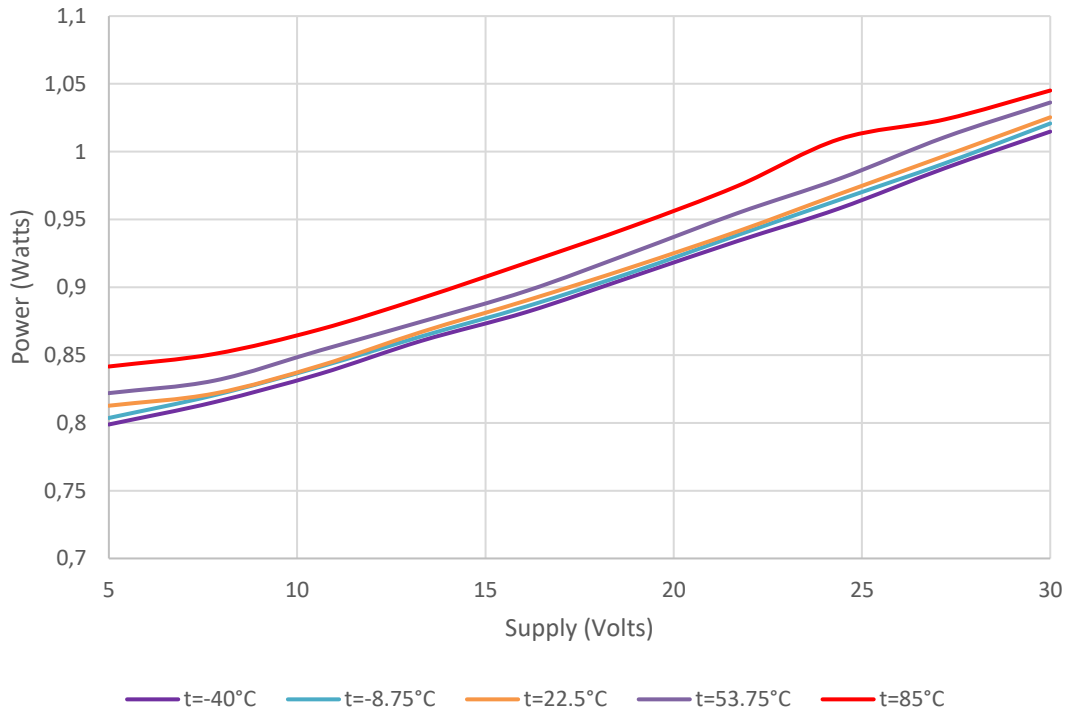

Figure 1 - MS-IMU3025 Power Consumption vs. Supply Voltage at 5 Temperatures

Inrush Peak Current

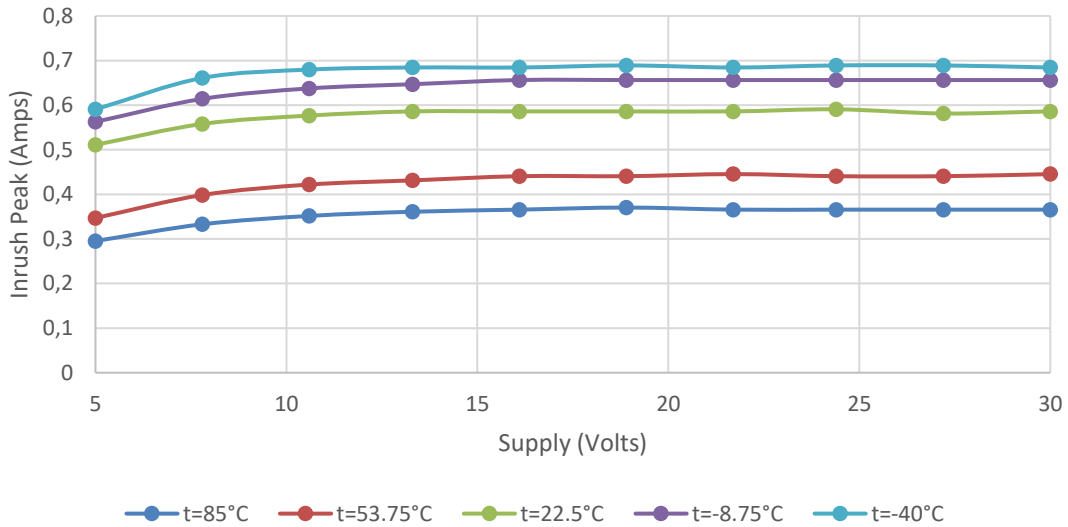

Figure 2 - MS-IMU3025 Inrush Peak Current vs. Supply Voltage at 5 Temperatures

MS-IMU3025 ALLAN DEVIATION CURVES

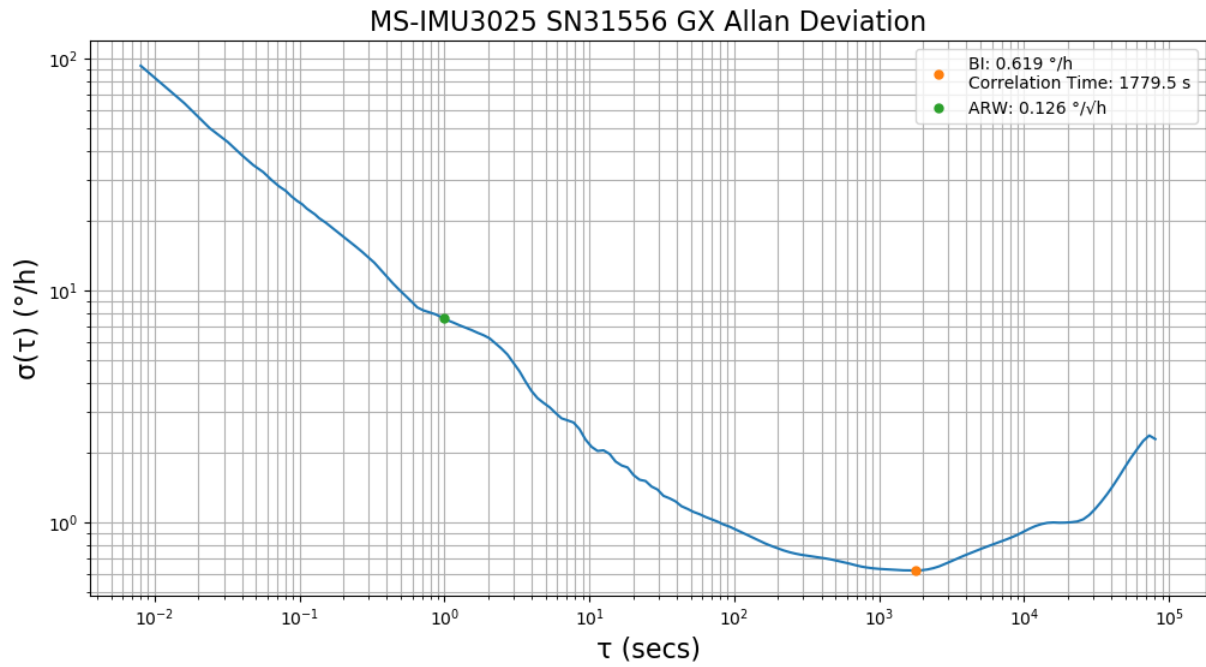

Figure 3 - MS-IMU3025 Example Gyro Allan Deviation

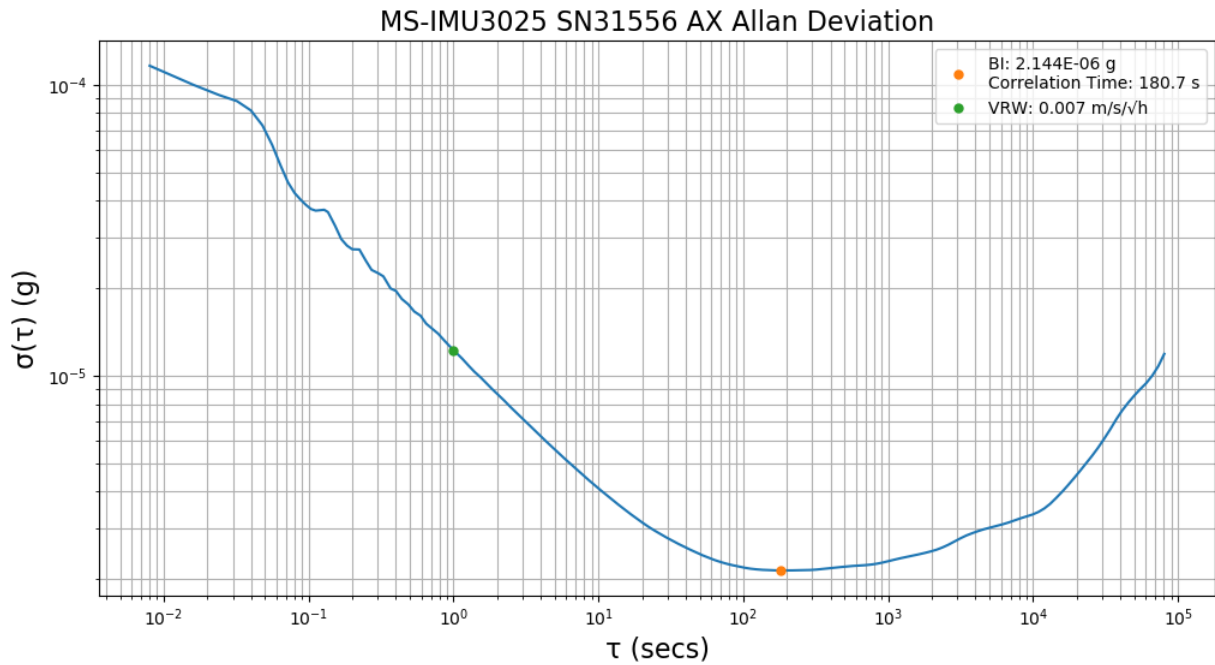

Figure 4 - MS-IMU3025 Example Accel Allan Deviation

3.0 MECHANICAL

3.1 Dimensions

The MS-IMU3025 is contained in a 6061-T6 aluminum housing anodized to MIL-A-8625 standards. Mounting of the IMU is achieved through four 2-56 captive socket head cap screws while alignment is facilitated through two one sixteenth inch dowel pins. The mounting surface of the mechanical interface is flat to within one one-thousandths of an inch. Detailed mechanical drawings in Imperial and Metric units are provided at Memsense.com under the MS-IMU3025 product page. Figure 5 and Figure 6 show the IMU unit's typical enclosure with and without clips on its connector, respectively. The dimensions below are only an overview of the housing.

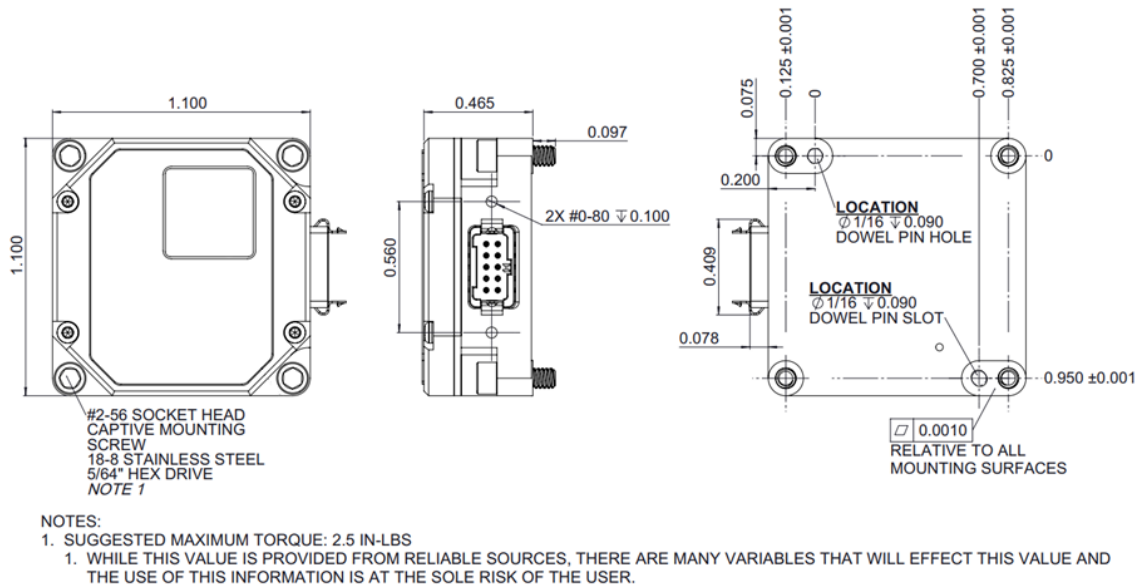

Figure 5 - Physical dimensions (inches). Connector with clips.

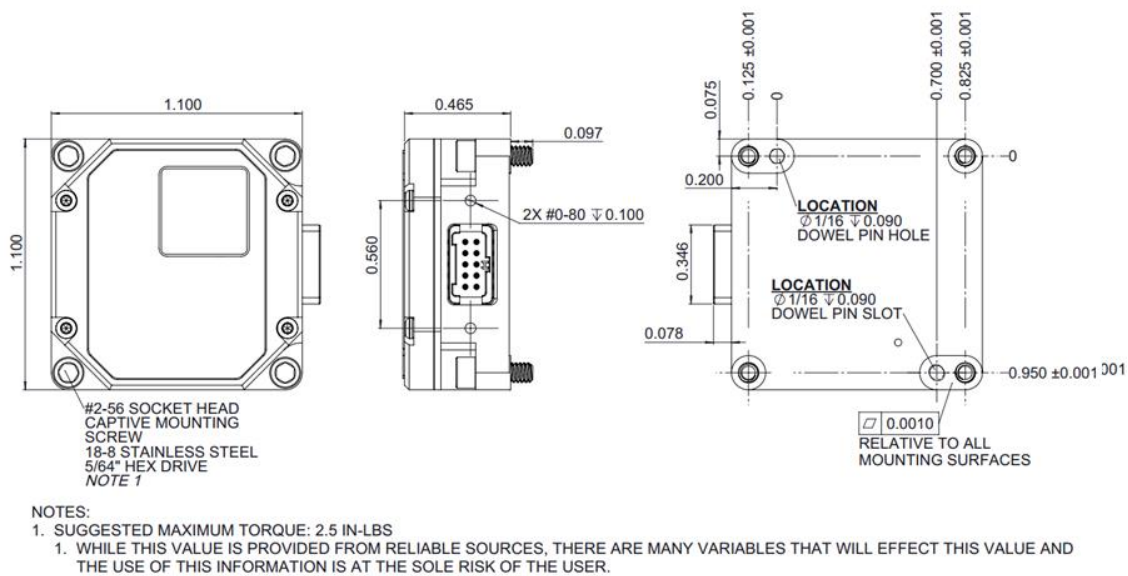

Figure 6 - Physical dimensions (inches). Connector without clips.

3.2 Coordinate System

The coordinate system for the MS-IMU3025 follows the right-hand rule convention. As an example, with the IMU pictured in Figure 2, if the Z axis is pointed straight UP away from the earth, it will produce 0 g for the X and Y axes and a positive 1 g for the Z axis. A counterclockwise rotation of the IMU about any of the depicted axis will produce a positive angular rate output for the corresponding axis. The magnetometer sign convention produces a positive output on the corresponding axis aligned in the North direction with the IMU bottom parallel and facing the Earth's surface.

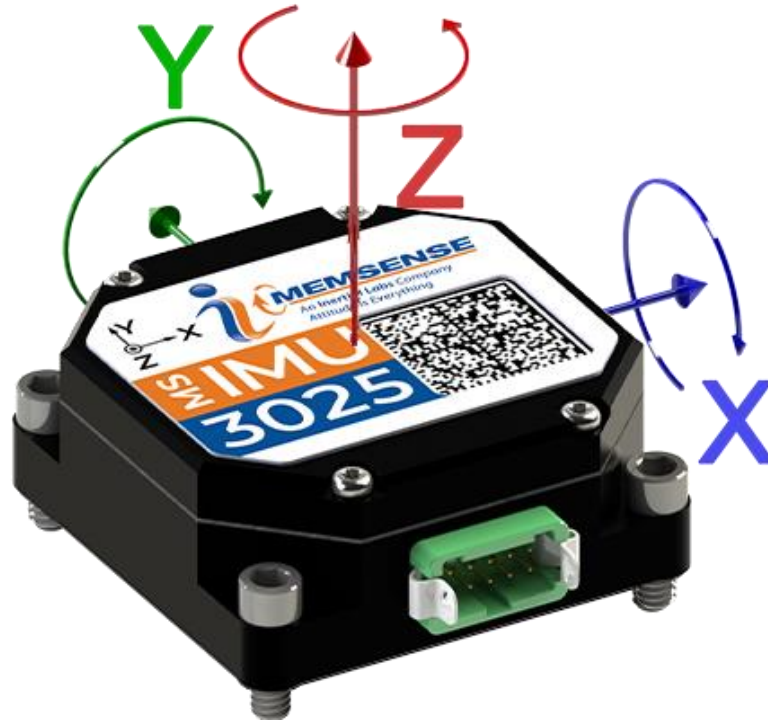

Figure 7 – MS-IMU3025 coordinate system

4.0 COMMUNICATIONS

4.1 Default Settings

The MS-IMU3025 is configured in manufacture to default settings. Knowledge of these settings is important when connecting to the IMU in the MS-CIP Evaluation Application. The following table provides the necessary default settings to connect to the IMU.

Table 5 –IMU Default Settings

SETTING	DEFAULT
Baud Rate	460800 bps
Start Bit	1
Stop Bit	1
Data Bits	8
Parity	None

4.2 Hardware Interface

The MS-IMU3025 utilizes a 1.25mm pitch 10-pin Harwin Gecko connector for an electrical interface. The IMU connector manufacturer part number is G125-MS11005L with a mating connector manufacturer part number of G125-2041096L0. The IMU communications are transmitted and received via 3.0-volt level RS-422 physical signals. The RS-422 differential inputs (pin 4 and 5) are internally terminated with a 120-ohm resistor. A system designed to communicate with the IMU should include a 120-ohm terminating resistor between the RS-422 differential outputs (pin 9 and 10). The electrical interface is further detailed in the figure and table below as well as sections 4.2.1 through 4.2.3.

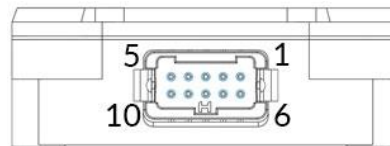

Figure 8 – MS-IMU3025 electrical interface connector

Table 6 – MS-IMU3025 Signal Interface

PIN	SIGNAL NAME	DESCRIPTION
1	PWR	Power Supply Input
2	RSVD	Reserved
3	1PPS	GPS 1 Pulse Per Second Input
4	RCV A	RS-422 Non-Inverting Input
5	RCV B	RS-422 Inverting Input
6	GND	Power Supply Return
7	TOV	Time Of Validity
8	X TRIG	External Trigger
9	TX Y	RS-422 Non-Inverting Output
10	TX Z	RS-422 Inverting Output

4.2.1 Time of Validity Output – Internal Sample Rate

The *Time of Validity (TOV)*, pin 7, output provides a signal that indicates when the internal sensors are sampled at the internal sample rate and when the samples complete transmission. The TOV falling edge is correlated with sampling of the first element in a sample. The TOV rising edge occurs after the last bit of a sample has finished transmission. Figure 8 provides a timing diagram depicting the relation between the internal sample rate, sample transmission and the TOV output. See 4.1.2 External Trigger Input for TOV output with external trigger enabled.

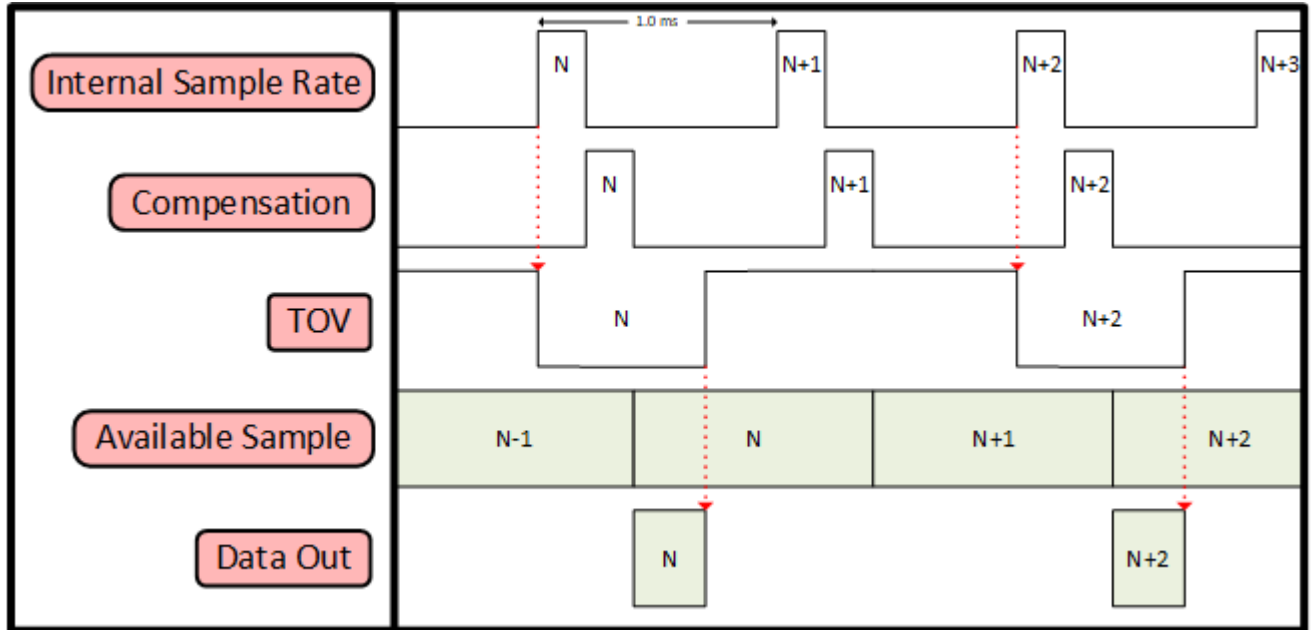

Figure 9 – TOV timing diagram with output sample rate at decimation of 2.

4.2.2 External Trigger Input

The *External Trigger (X TRIG)*, pin 8, input provides a means to synchronize the IMU’s sample transmission with an external sampling period. A rising edge signal on the External Trigger input initiates the transmission of the most recent complete sample. When in the External Trigger Mode, the TOV falling edge occurs with the beginning of an internal sample and its rising edge is initiated by the completion of the sample’s compensation. Figure 9 depicts the timing associated with the use of the External Trigger and its relation to the TOV signal.

Please note that the External Trigger Mode must be enabled through the communications protocol for the input to be active, see the protocol section or the MS-CIP specification for details on enabling or disabling the External Trigger.

4.2.3 1 Pulse Per Second Input

The *1 Pulse Per Second Input (1 PPS)*, pin 3, provides a means to synchronize the IMU’s sample transmission with a GPS receiver’s 1 pulse per second output. A Rising Edge signal on the 1 PPS input time initiates a time reset to the nearest second.

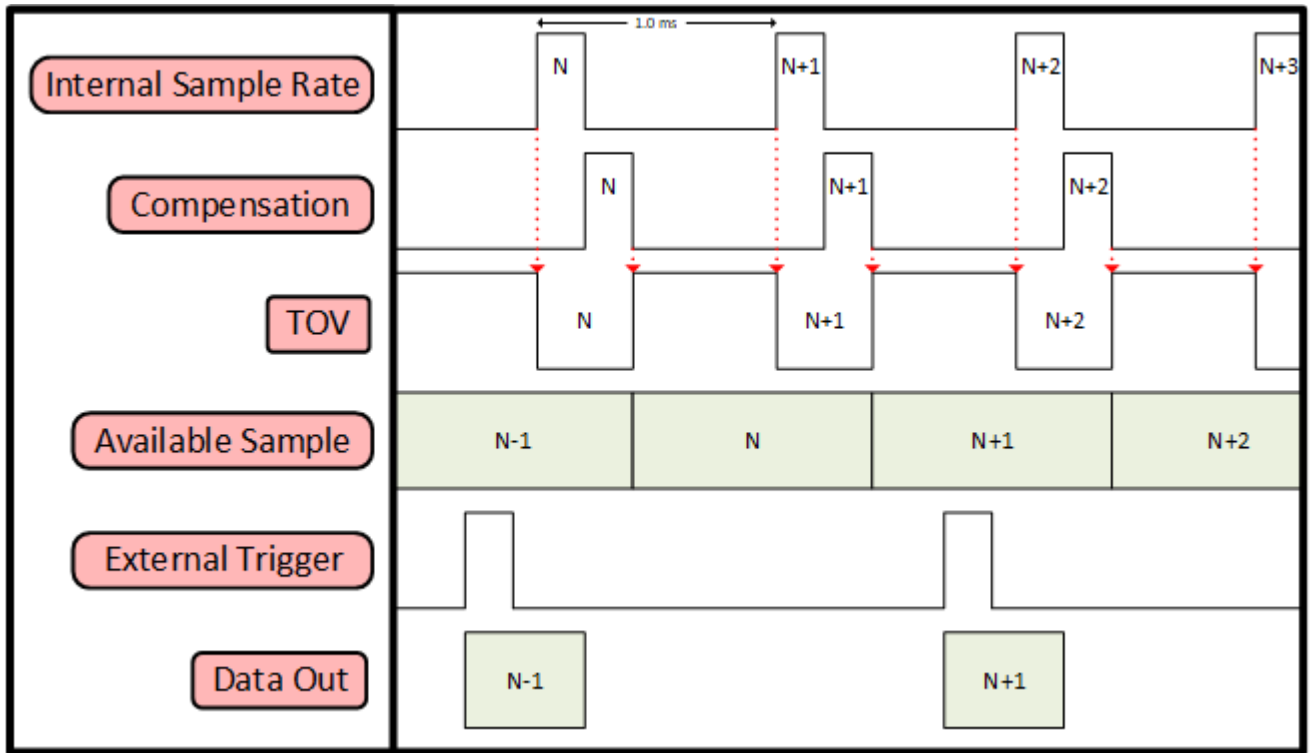

Figure 10 – External Trigger timing diagram.

4.3 Internal Sample Rate

The MS-IMU3025 internally samples sensors selected by the configuration at a rate of 1000 samples per second. The internal sample rate is used in the output sample rate configuration detailed in the Memsense Communication Interface Protocol.

4.4 Communication Interface Protocol

The communication interface protocol is defined in detail in the Memsense Communication Interface Protocol document (MS-CIP DOC00381) which can be found on the MS-IMU3025 product page at Memsense.com. The following information provides an overview and contains MS-IMU3025 specific portions of the communication protocol.

The Memsense Communication Interface Protocol (MS CIP) is implemented as a simple architecture to communicate information to and from the measurement device. The protocol is intended to be flexible in allowing customers to configure various features of the device achieving optimized communication modes for various application requirements. Below is a table showing the default output from the MS-IMU3025.

Table 7 – Default IMU Data Message 0xA2

BYTE	BYTE NAME	VALUE	DESCRIPTION
0	Sync1	0xA5	First synchronization value used in sample parsing.
1	Sync2	0xA5	Second synchronization value used in sample parsing.
2	Message Type	0xA2	Message type identification code.
3	Payload Size	0x1C	Byte length of the payload.
4	Message Code	0x81	Scaled Acceleration Vector identification code.
5	Data Size	0x0C	Data Size in bytes.
6	X Accel MSB	0x37	X Accel in g. MSB of F32.
7	X Accel Byte 2	0xA7	X Accel in g. Byte 2 of F32.
8	X Accel Byte 1	0xC5	X Accel in g. Byte 1 of F32.
9	X Accel LSB	0xAC	X Accel in g. LSB of F32.
10	Y Accel MSB	0x37	Y Accel in g. MSB of F32.
11	Y Accel Byte 2	0x7B	Y Accel in g. Byte 2 of F32.
12	Y Accel Byte 1	0xA8	Y Accel in g. Byte 1 of F32.
13	Y Accel LSB	0x82	Y Accel in g. LSB of F32.
14	Z Accel MSB	0x3F	Z Accel in g. MSB of F32.
15	Z Accel Byte 2	0x80	Z Accel in g. Byte 2 of F32.
16	Z Accel Byte 1	0x00	Z Accel in g. Byte 1 of F32.
17	Z Accel LSB	0x65	Z Accel in g. LSB of F32.
18	Message Code	0x82	Scaled Angular Rate Vector identification code.
19	Data Size	0x0C	Data Size in bytes.
20	X Gyro MSB	0x37	X Gyro in degrees per second. MSB of F32.
21	X Gyro Byte 2	0xA7	X Gyro in degrees per second. Byte 2 of F32.
22	X Gyro Byte 1	0xC5	X Gyro in degrees per second. Byte 1 of F32.
23	X Gyro LSB	0xAC	X Gyro in degrees per second. LSB of F32.
24	Y Gyro MSB	0x37	Y Gyro in degrees per second. MSB of F32.
25	Y Gyro Byte 2	0x7B	Y Gyro in degrees per second. Byte 2 of F32.
26	Y Gyro Byte 1	0xA8	Y Gyro in degrees per second. Byte 1 of F32.
27	Y Gyro LSB	0x82	Y Gyro in degrees per second. LSB of F32.
28	Z Gyro MSB	0x37	Z Gyro in degrees per second. MSB of F32.
29	Z Gyro Byte 2	0x49	Z Gyro in degrees per second. Byte 2 of F32.
30	Z Gyro Byte 1	0x53	Z Gyro in degrees per second. Byte 1 of F32.
31	Z Gyro LSB	0x9C	Z Gyro in degrees per second. LSB of F32.
32	Checksum 1	0x0C	Fletcher-16 checksum block 1 MSB
33	Checksum 2	0x23	Fletcher-16 checksum block 2 LSB
Resulting Complete Command			

A5A5A21C810C37A7C5AC377BA8823F800065820C37A7C5AC377BA8823749539C0C23

4.4.1 IMU Sample Rate Configure 0x0204

The *IMU Sample Rate Configure* provides a means to configure and save the rate at which all IMU data messages are transmitted. *IMU Message Config* is used to control individual measurements.

The *IMU Sample Rate Configure* function codes define the function to be performed on the device's inertial measurements. The associated codes and functions are listed in Table 8 below.

Table 8 – IMU Sample Rate Function Codes

CODE	IMU SAMPLE RATE FUNCTION
0X01	Use new settings.
0x02	Request current settings.
0x03	Save current settings as startup settings.
0x04	Load saved startup settings.
0x05	Reset to default settings.

A 16-bit decimation value must be provided and is used to divide the internal sample rate to the desired output sample rate. The MS-IMU3025 has an internal sample rate of 1000Hz therefore providing a decimation value of 0x0008 (8 decimal) configures the output sample rate to 125Hz.

See the MS-CIP at Memsense.com under the MS-IMU3025 product page for more details regarding IMU Sample Rate Configure.

4.4.2 Configure Filter 0x0203

The *Configure Filter* message provides a means for configuring and saving internal digital filtering options. The *Filter Function* allows the configuration to be used, queried, saved, loaded from startup settings, and reset to defaults. Table 9 details the associated codes and functions.

Table 9 –Filter Function Codes

CODE	FILTER FUNCTION
0X01	Use new settings.
0x02	Request current settings.
0x03	Save current settings as startup settings.
0x04	Load saved startup settings.
0x05	Reset to default settings.

The *Filter Control* codes allow filtering to be disabled or enabled in Infinite Impulse Response (IIR) mode. Care in selecting a filter bandwidth value that supports the Nyquist Sampling Theorem is suggested. The filter cutoff options listed here are specific to the MS-IMU3025. Filter cutoff options for the MS-IMU3025 are listed in Table 10.

Table 10 – Filter Bandwidth Control Codes

CODE	FILTER CONTROL CODES
0x00	Disable Filter
0x01	IIR Filter -3 dB at 25Hz
0x02	IIR Filter -3 dB at 50Hz (Default)
0x03	IIR Filter -3 dB at 75Hz
0x04	IIR Filter -3 dB at 100Hz
0x05	IIR Filter -3 dB at 10Hz
0x06	IIR Filter -3 dB at 150Hz
0x07	IIR Filter -3 dB at 200Hz

4.4.3 Select Sensors 0x0205

The *Select Sensors* message provides a means to configure and save the contents of the IMU data messages transmitted.

The *Select Sensors* function codes define the function to be performed on the device's message format. The associated codes and functions for the MS-IMU3025 are listed in Table 11 below.

Table 11 – Select Sensors Function Codes

CODE	SELECT SENSORS FUNCTION
0x01	Use new settings.
0x02	Request current settings.
0x03	Save current settings as startup settings.
0x04	Load saved startup settings.
0x05	Reset to default settings.

Table 12 lists the codes for the available measurements to be selected.

Table 12 – Select Sensors Options

CODE	SELECT SENSORS OPTIONS
0x81	Scaled Acceleration Vector in g
0x82	Scaled Angular Rate Vector in deg/sec
0x83	Scaled Magnetic Field Vector in gauss
0x84	Delta Theta Vector in Radians
0x85	Delta Velocity Vector in m/s
0x87	Scaled Temperature in Celsius
0x88	GPS Correlated Time

For each measurement selected the associated data code must be provided. When a Select Sensor message requests a sensor option that doesn't exist in the IMU (magnetometer or pressure), a NACK message will be returned.

See the MS-CIP at Memsense.com under the MS-IMU3025 product page for more details regarding Select Sensors.

4.4.4 Config Accel Range 0x0207

The MS-IMU3025 supports the configuration of accelerometer dynamic ranges. The following configuration information details the options available and associated codes used in the communication protocol.

The *Config Accel Range* message provides a means for configuring and saving the triaxial accelerometer dynamic range options.

The *Config Accel Range Function* allows the configuration to be used, queried, saved, loaded from startup settings, and reset to defaults. Table 13 details the associated codes and functions.

Table 13 –Config Accel Range Function Codes

CODE	CONFIGURE ACCEL RANGE FUNCTION CODES
0X01	Use new settings.
0x02	Request current settings.
0x03	Save current settings as startup settings.
0x04	Load saved startup settings.
0x05	Reset to default settings.

The *Accel Range* codes allow the dynamic range of the accelerometer to be changed to one of the 3 supported ranges and effect all three axes of the sensor. The options for the accelerometer dynamic range are controlled in the *Accel Range Codes* listed in Table 14.

Table 14 – Accel Range Codes

CODE	ACCEL RANGE CODES
0x00	Accelerometer range $\pm 2 g$
0x01	Accelerometer range $\pm 4 g$ (Default)
0x02	Accelerometer range $\pm 8 g$
0x05	Accelerometer range $\pm 20 g$
0x06	Accelerometer range $\pm 40 g$

4.4.5 Config Gyro Range 0x0208

The MS-IMU3025 supports the configuration of gyroscope dynamic ranges. The following configuration information details the options available and associated codes used in the communication protocol.

The *Config Gyro Range* message provides a means for configuring and saving the triaxial gyroscope dynamic range options.

The *Config Gyro Range Function* allows the configuration to be used, queried, saved, loaded from startup settings, and reset to defaults. Table 15 details the associated codes and functions.

Table 15 – Config Gyro Range Function Codes

CODE	CONFIGURE GYRO RANGE FUNCTION CODES
0X01	Use new settings.
0x02	Request current settings.
0x03	Save current settings as startup settings.
0x04	Load saved startup settings.
0x05	Reset to default settings.

The *Gyro Range* codes allow the dynamic range of the gyroscope to be changed to 1 of the 5 supported ranges and effect all 3 axes of the sensor. The options for the gyroscope dynamic range are controlled in the *Gyro Range Codes*. The MS-IMU3025 codes are listed in Table 16.

Table 16 – MS-IMU3025 Gyro Range Codes

CODE	GYRO RANGE CODES
0x06	Gyroscope range ± 75 °/s
0x07	Gyroscope range ± 200 °/s
0x03	Gyroscope range ± 480 °/s (Default)
0x04	Gyroscope range ± 960 °/s
0x05	Gyroscope range ± 1920 °/s

5.0 ROHS COMPLIANCE

5.1 RoHS Compliance Statement

There are two models of the MS-IMU3025 that are RoHS compliant, the MS-IMU3025MR and MS-IMU3025R. Memsense has reviewed all components of these product models and verified that they are RoHS compliant. Table 17 details the audit that was performed to verify compliance.

Table 17 – MS-IMU3025MR and MS-IMU3025R RoHS Compliance Audit

Component	Method of Audit	Compliant
PCB	Finishes Research	Yes
Solder Paste	Technical Datasheet	Yes
Wire Solder	Declaration of Conformity	Yes
Sealant	SDS Review	Yes
Integrated Circuits, Discrete Components, Connectors	Silicon Expert Report	Yes
Housing	Material Certificates	Yes
Housing Finish	Manufacturer Statement	Yes
Encapsulant	Review of SDS	Yes
Gaskets	Material Certificate	Yes
Graphic Overlay	Material Certificates, Vendor Statement	Yes
Labels	Manufacturer Compliance Document	Yes
Hardware – 18-8 Stainless Steel	Distributor Statement	Yes

6.0 OPTIONS

6.1 Part Numbering

The standard part numbers, sensor ranges, RoHS compliance, and associated ECCNs for the MS-IMU3025 are listed in the table below. MS-IMU3025 models are classified as 7A994 for export. This classification is the same as no license required for individuals and countries not on the banned list.

Table 18 – Standard Part Numbers

Model Number	Part Number	Accel (g)	Rate (°/s)	Mag (gauss)	RoHS	ECCNs
MS-IMU3025M	MP00075-001	±2, ±4, ±8, ±20, ±40	±75, ±200, ±480, ±960, ±1920	±2	Noncompliant	7A994
MS-IMU3025	MP00075-002	±2, ±4, ±8, ±20, ±40	±75, ±200, ±480, ±960, ±1920	None	Noncompliant	7A994
MS-IMU3025MR	MP00075-101	±2, ±4, ±8, ±20, ±40	±75, ±200, ±480, ±960, ±1920	±2	Compliant	7A994
MS-IMU3025R	MP00075-102	±2, ±4, ±8, ±20, ±40	±75, ±200, ±480, ±960, ±1920	None	Compliant	7A994
MS-IMU3025S1*	MP00075-004	±2, ±4, ±8, ±20, ±40	±75, ±200, ±480, ±960, ±1920	None	Noncompliant	7A994

*MS-IMU3025S1 is identical to the MS-IMU3025 except without connector latches, see Figure 6 for details.

6.2 IMU Accessories

Accessories available for the MS-IMU3025 include interface cables, a USB data acquisition module (USB-DAQ) and the MS-IMU3025 configuration software. The accessories allow an end user to rapidly connect, configure and collect evaluation data with the MS-IMU3025. The software provides valuable tools used in developing communications with the IMU. The table below provides the accessory part number details.

Table 19 – Accessories Part Numbers

Model Number	Part Number	Description
C30X0-G10F-H6F-36	MP00063-001	MS-IMU3025 36-inch Development Interface Cable
C30X0-G10F-PTL-08	MP00063-003	MS-IMU3025 8-inch Unterminated Interface Cable
C30X0-G10F-PTL-12	MP00063-004	MS-IMU3025 12-inch Unterminated Interface Cable
USB-DAQ	MP00082-101	USB IMU Data Interface Module, 36"
MS-CIP-EVAL	N/A	MS-IMU3025 Configuration Software

6.3 IMU Development Kit

Development kits available for the MS-IMU3025 are listed in Table 20 below.

Table 20 – Development Kit

Dev Kit Part Number	#	Part Number	Content Description
MP00087-001	1	CM01614	USB 2.0 A to Micro-USB B Cable 3FT
	2	CM01667	Box, Memsense Development Kit
	3	MP00063-018	Cable 36IN Gecko (F) to Gecko (F)
	4	MP00063-019	Cable 36IN Gecko (M) to Gecko (F)
	5	MP00069-001	USB Drive MS-CIP Evaluation Application and User Manual
	6	MP00082-101	USB IMU Data Interface Module, 36"
	7	MP00083-101	IMU Breakout Development Board
	8	MP00084-101	USB IMU Data Interface Module External Power Adapter
	9	MP00085-001	USB-DAQ External Power Cable

6.4 IMU Evaluation Kit

Evaluation Kits available for the MS-IMU3025 are listed in Table 21 below.

Table 21 – Evaluation Kit

Eval Kit Part Number	#	Part Number	Content Description
MP00088-001	1	CM01667	Box, Memsense Development Kit
	2	MP00063-019	Cable 36IN Gecko (M) to Gecko (F)
	3	MP00069-001	USB Drive MS-CIP Evaluation Application and User Manual
	4	MP00082-101	USB IMU Data Interface Module, 36"
	5	MP00084-101	USB IMU Data Interface Module External Power Adapter
	6	MP00085-001	USB-DAQ External Power Cable