



**MS IMU  
3030**

## Product Specification & User Guide

Document Number: DOC00593

Document Revision: N

Product Model Number: MS-IMU3030

Product Part Number: MP00066

[MEMSENSE.COM](http://MEMSENSE.COM)

888.668.8743

## TABLE OF CONTENTS

<b>1.0 Overview</b> .....	<b>1</b>
<b>2.0 Specifications</b> .....	<b>1</b>
<b>3.0 Mechanical</b> .....	<b>6</b>
3.1 Dimensions .....	6
3.2 Coordinate System.....	7
<b>4.0 Communications</b> .....	<b>8</b>
4.1 Default Settings.....	8
4.2 Hardware Interface.....	8
4.2.1 Time of Validity Output – Internal Sample Rate .....	9
4.2.2 External Trigger Input.....	9
4.2.3 Pulse Per Second Input.....	9
4.3 Internal Sample Rate.....	10
4.4 Communication Interface Protocol.....	10
4.4.1 IMU Sample Rate Configure 0x0204 .....	12
4.4.2 Configure Filter 0x0203 .....	12
4.4.3 Select Sensors 0x0205 .....	13
4.4.4 Config Accel Range 0x0207 .....	14
4.4.5 Config Gyro Range 0x0208.....	15
<b>5.0 Options</b> 16	
5.1 Part Numbering .....	16
5.2 IMU Accessories .....	16
5.3 IMU Development Kit.....	17
5.4 IMU Evaluation Kit.....	17

## 1.0 OVERVIEW

The MS-IMU3030 MEMS Inertial Measurement Unit delivers leading performance in a miniature package. The gyro bias instability of 0.55 °/h and accelerometer bias instability of 3.7 μg supply ample inertial performance to support a wide range of applications from navigation and control to pipeline inspection. User configurable options allow the IMU to be tuned to your application with configurable bandwidth, sample rate, gyro ranges, accel ranges, 1 PPS input and other measurement parameters. An auxiliary accelerometer that can be configured to ±40 g allows incredible application tuning flexibility. The IMU provides all these features in a package that only measures 1.1 x 1.1 x 0.45 inches with a mass of only 25 grams.

The MS-IMU3030's combination of inertial performance, size, and configurability surpasses all IMUs in the market.



## 2.0 SPECIFICATIONS

**Table 1 – Specifications**

ACCELEROMETER IN PNS:	MP00066-001, -002 & -102			UNITS	NOTES
Dynamic Range	± 2	± 4	± 8	g	Note 1
Bias Instability	1.59		1.94	μg	Typical XY
	6.48		6.93		Typical Z
Bias Offset	± 383		± 341	μg	XY Typical
	± 1959		± 1886		XY Maximum
	± 485		± 363		Z Typical
	± 1982		± 1880		Z Maximum, Note 2
Bias Temperature Coefficient	11.51		9.92	μg/°C	Typical
	19.24		18.37		Maximum, Note 3
Nonlinearity			± 0.3	% of FS	Typical, Note 4
Scale Factor Error	± 1205		± 473	ppm	Typical XY
	± 2088		± 1340		Maximum XY
	± 3243		± 354		Typical Z
	± 4700		± 1098		Maximum Z
Scale Factor Temperature Coefficient	7.14		1.50	ppm/°C	Typical XY
	12.86		3.45		Maximum XY
	17.36		13.11		Typical Z
	20.96		17.77		Maximum Z
Velocity Random Walk	0.0050		0.0058	m/s/h <sup>-1/2</sup>	Typical XY
					Typical Z
	0.0073		0.0079		
Noise Density				μg/Hz <sup>-1/2</sup>	Typical XY
			20		Maximum XY
					Typical Z
Bandwidth				Hz	Maximum Z
			50		-3dB point, Note 5

ACCELEROMETER IN PNS:		MP00066-003 & -004			UNITS	NOTES
Dynamic Range	± 10	± 20	± 40	g	Note 1	
Bias Instability				10.6	µg	Typical
Offset				±1400	µg	Typical, Note 2
Bias Temperature Coefficient	18.46			10.47	µg	Typical
	33.70			18.35		Maximum, Note 3
Nonlinearity				± 0.3	% of FS	Typical, Note 4
Scale Factor Error	± 741			± 443	ppm	Typical XY
	± 1813			± 1023		Maximum XY
	± 2398			± 323		Typical Z
	± 4178			± 1148		Maximum Z
Scale Factor Temperature Coefficient	11.51			2.80	ppm/°C	Typical XY
	24.86			5.40		Maximum XY
	31.19			13.81		Typical Z
	41.07			18.96		Maximum Z
Velocity Random Walk				0.028	m/s/h <sup>-1/2</sup>	Typical
Noise Density				63.6	µg/Hz <sup>-1/2</sup>	Typical
Bandwidth				50	Hz	-3dB point, Note 5
ACCELEROMETER IN PNS:		MP00066-007 & -008			UNITS	NOTES
Dynamic Range	± 10	± 20	± 40	g	Note 1	
Bias Instability				10.6	µg	Typical
Bias Offset	± 1032			± 331	µg	Typical XY
	± 3653			± 1809		Maximum XY, Note 2
	± 1112			± 309		Typical Z
	± 4159			± 1990		Maximum Z, Note 2
Bias Temperature Coefficient	18.46			10.47	µg	Typical
	33.70			18.35		Maximum, Note 3
Scale Factor Error	± 741			± 443	ppm	Typical XY
	± 1813			± 1023		Maximum XY
	± 2398			± 323		Typical Z
	± 4178			± 1148		Maximum Z
Scale Factor Temperature Error	11.51			2.80	ppm/°C	Typical XY
	24.86			5.40		Maximum XY
	31.19			13.81		Typical Z
	41.07			18.96		Maximum Z
Nonlinearity	± 0.3	± 0.3	± 0.3	% of FS	Typical, Note 4	
Velocity Random Walk	0.028	0.028	0.028	m/s/h <sup>-1/2</sup>	Typical	
Noise Density	63.6	63.6	63.6	µg/Hz <sup>-1/2</sup>	Typical	
Bandwidth				50	Hz	-3dB point, Note 5

ANGULAR RATE						UNITS	NOTES	
Dynamic Range	± 75	± 200	± 480	± 960	± 1920	°/s	Min, Note 1	
Bias Instability						0.46	°/h	Typical XY
						0.51		Typical Z
Bias Offset						± 14.20	°/h	Typical
						± 100.00		Maximum, Note 2
Bias Temperature Coefficient						0.58	°/h/°C	Typical
						1.20		Maximum, Note 3
Bias G-Sensitivity						2.19	°/h/g	Typical
Scale Factor Error						± 836	ppm	XY Typical
						± 1870		XY Maximum
						± 629		Z Typical
						± 1290		Z Maximum
Scale Factor Temperature Coefficient						13.66	ppm/°C	XY Typical
						17.27		XY Maximum
						3.07		Z Typical
						12.32		Z Maximum
Nonlinearity						± 0.05	% of FS	Typical, Note 4
Angle Random Walk						0.114	°/h <sup>-1/2</sup>	Typical XY
						0.106		Typical Z
Noise Density						0.003	°/s /Hz <sup>-1/2</sup>	Typical
Bandwidth						50	Hz	-3dB point, Note 5
MAGNETIC FIELD		NOTE 6 & 7				UNITS	NOTES	
Dynamic Range						± 1.9	gauss	Minimum
Offset						± 0.015	gauss	Typical
Noise Density						79.2	µgauss /Hz <sup>-1/2</sup>	Typical
Bandwidth						50	Hz	-3dB point
DEVICE TEMPERATURE						UNITS	NOTES	
Temperature Error						± 1.5	°C	Maximum
1 PULSE PER SECOND INPUT								
Voltage Low Level Input						0.9	V	Maximum
Voltage High Level Input						2.1	V	Minimum
Trigger Edge						Rising		
EXTERNAL TRIGGER INPUT								
Voltage Low Level Input						0.9	V	Maximum
Voltage High Level Input						2.1	V	Minimum
Pulse Width						1.0	µs	Minimum
TIME OF VALIDITY OUTPUT								
Voltage Low Level Output						0.4	V	Maximum
Voltage High Level Output						2.6	V	Minimum
Rise and Fall Time						30	ns	Maximum
PHYSICAL						UNITS	NOTES	
Dimensions	1.10 × 1.10 × 0.45					in.	(L x W x H)	
Mass						25	grams	
OPERATIONAL REQUIREMENTS						UNITS	NOTES	
Supply Voltage	4.9 to 30.0					VDC		
Supply Power	1.35					W	Typical	
Operating Temperature	-40 to 85					°C		
Interface Connector	Harwin Gecko G125-MS11005L						10 pin	
Mating Connector	Harwin Gecko G125-2041096L0						10 pin	

ABSOLUTE MAXIMUM	NOTE 8	UNITS	NOTES
Acceleration Powered	800	<i>g</i>	0.5 ms any axis
Supply Voltage	-0.3 (min) to 36.0 (max)	VDC	
Storage Temperature	-55 to 85	°C	
Maximum Digital Input, Unpowered	3.3	VDC	

Note 1: Dynamic ranges configurable, see Section 4.4.4 Config Accel Range and Section 4.4.5 Config Gyro Range.

Note 2: Bias Offset determine from maximum absolute bias at ambient temperature.

Note 3: Bias Temperature Coefficient is determined from maximum minus minimum bias over operating environment temperature with  $\pm 1$  °C/min. gradient.

Note 4: Nonlinearity is specified from -30 to 85 °C. For gyros an input angular rate of  $\pm 450$  °/s is used.

Note 5: Bandwidth is configurable, see Section 4.4.2 Configure Filter.

Note 6: Typical Values at 25°C, 0 °/s, unless otherwise noted.

Note 7: See Table 14 for applicability to model numbers.

Note 8: Absolute Maximum Ratings list device survivability specifications and are non-operational.

MS-IMU3030 ALLAN VARIANCE CURVES

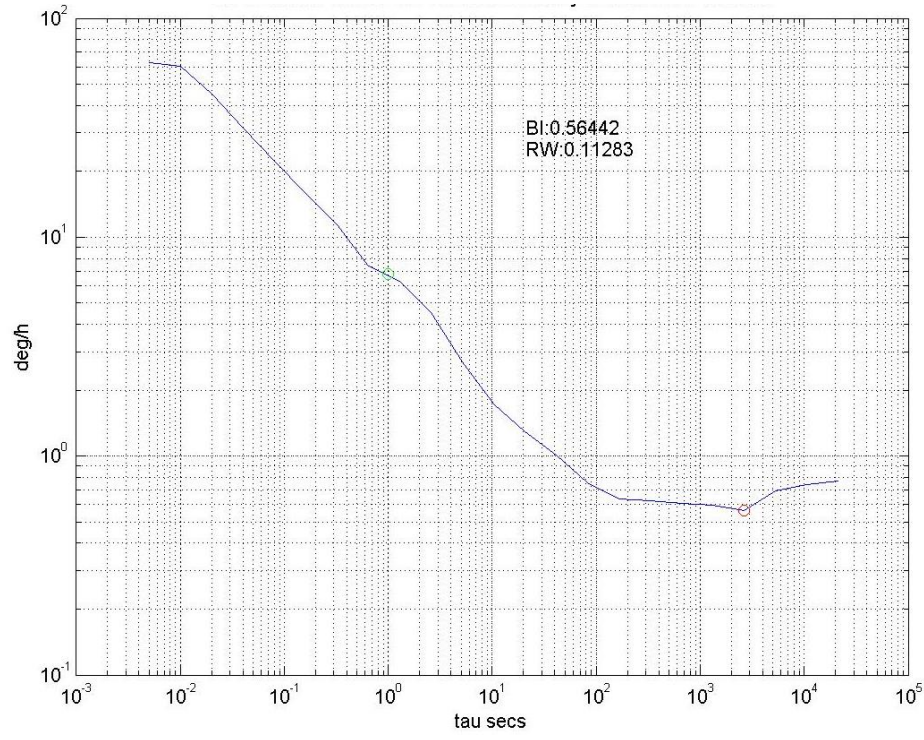

Figure 1 – MS-IMU3030 Gyro Root Allan Variance Obsolete

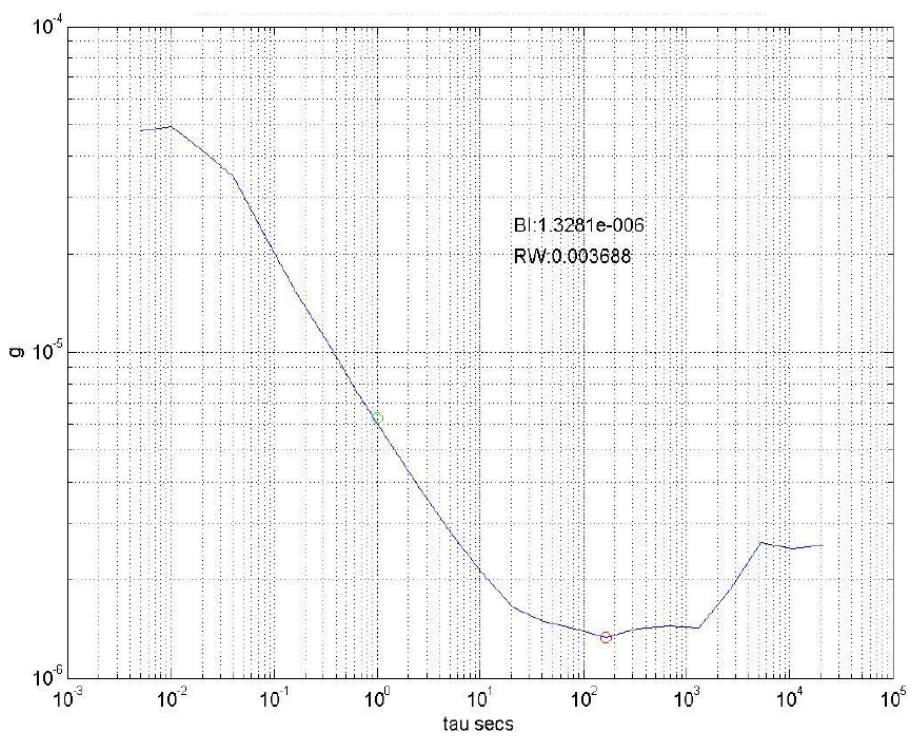

Figure 2 – MS-IMU3030 Primary Accel Root Allan Variance

3.0 MECHANICAL

3.1 Dimensions

The MS-IMU3030 is contained in a 6061-T6 aluminum housing anodized to MIL-A-8625 standards. Mounting of the IMU is achieved through four 2-56 captive socket head cap screws while alignment is facilitated through two one sixteenth inch dowel pins. The mounting surface of the mechanical interface is flat to within one one-thousandths of an inch. The dimensions below are only an overview of the housing, detailed mechanical drawings in Imperial and Metric units are provided at Memsense.com under the MS-IMU3030 product page.

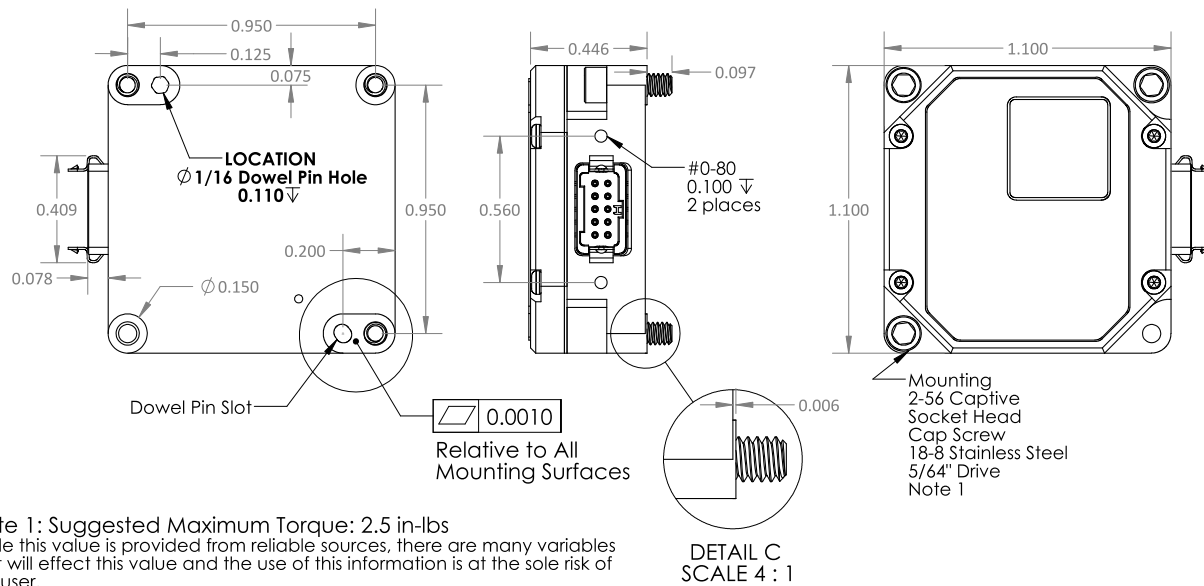

Figure 3 – Physical dimensions (inches)

### 3.2 Coordinate System

The coordinate system for the MS-IMU3030 follows the right-hand rule convention. As an example, with the IMU pictured in Figure 2, if the Z axis is pointed straight UP away from the earth, it will produce 0 *g* for the X and Y axes and a positive 1 *g* for the Z axis. A counterclockwise rotation of the IMU about any of the depicted axis will produce a positive angular rate output for the corresponding axis. The magnetometer sign convention produces a positive output on the corresponding axis aligned in the North direction with the IMU bottom parallel and facing the Earth's surface.

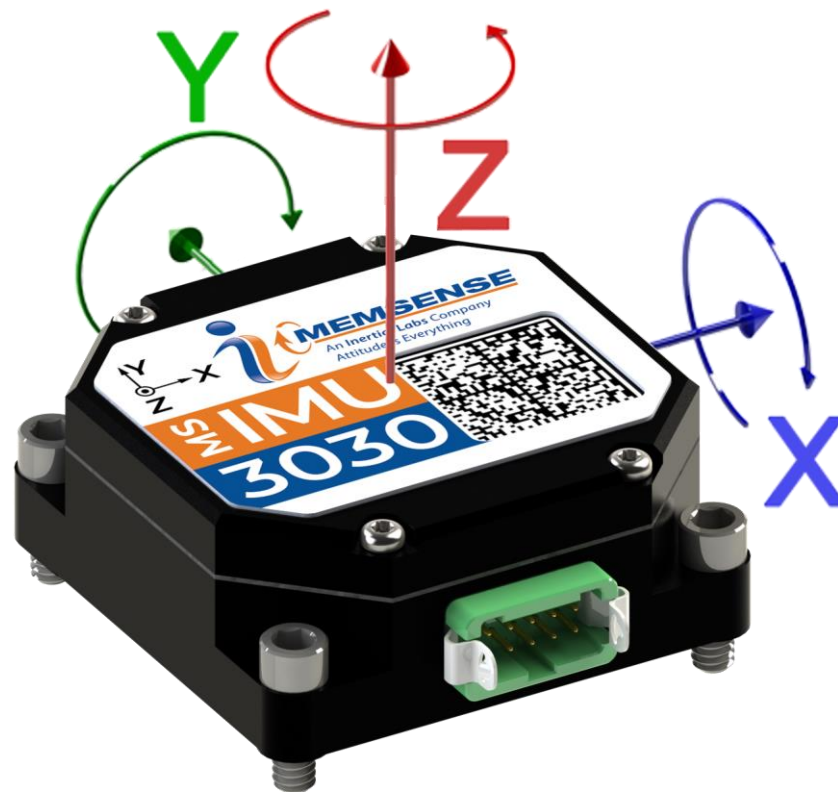

Figure 4 – MS-IMU3030 coordinate system

4.0 COMMUNICATIONS

### 4.1 Default Settings

The MS-IMU3030 is configured in manufacture to default settings. Knowledge of these settings is important when connecting to the IMU in the MS-CIP Evaluation Application. The following table provides the necessary default settings to connect to the IMU.

**Table 2 –IMU Default Settings**

SETTING	DEFAULT
Baud Rate	460800 bps
Start Bit	1
Stop Bit	1
Data Bits	8
Parity	None

### 4.2 Hardware Interface

The MS-IMU3030 utilizes a 1.25mm pitch 10-pin Harwin Gekco connector for an electrical interface. The IMU connector manufacturer part number is G125-MS11005L with a mating connector manufacturer part number of G125-2041096L0. The IMU communications are transmitted and received via 3.0-volt level RS-422 physical signals. The electrical interface is further detailed in the figure and table below as well as sections **Error! Reference source not found.** through 4.2.3.

**Figure 5 – MS-IMU3030 electrical interface connector**

**Table 3 – MS-IMU3030 Signal Interface**

PIN	SIGNAL NAME	DESCRIPTION
1	PWR	Power Supply Input
2	RSVD	Reserved
3	1PPS	GPS 1 Pulse Per Second Input
4	RCV A	RS-422 Non-Inverting Input
5	RCV B	RS-422 Inverting Input
6	GND	Power Supply Return
7	TOV	Time Of Validity
8	X TRIG	External Trigger
9	TX Y	RS-422 Non-Inverting Output
10	TX Z	RS-422 Inverting Output

### 4.2.1 Time of Validity Output – Internal Sample Rate

The *Time of Validity (TOV)*, pin 7, output provides a signal that indicates when the internal sensors are sampled at the internal sample rate and when the samples complete transmission. The TOV falling edge is correlated with sampling of the first element in a sample. The TOV rising edge occurs after the last bit of a sample has finished transmission. Figure 4 provides a timing diagram depicting the relation between the internal sample rate, sample transmission and the TOV output. See 4.1.2 External Trigger Input for TOV output with external trigger enabled.

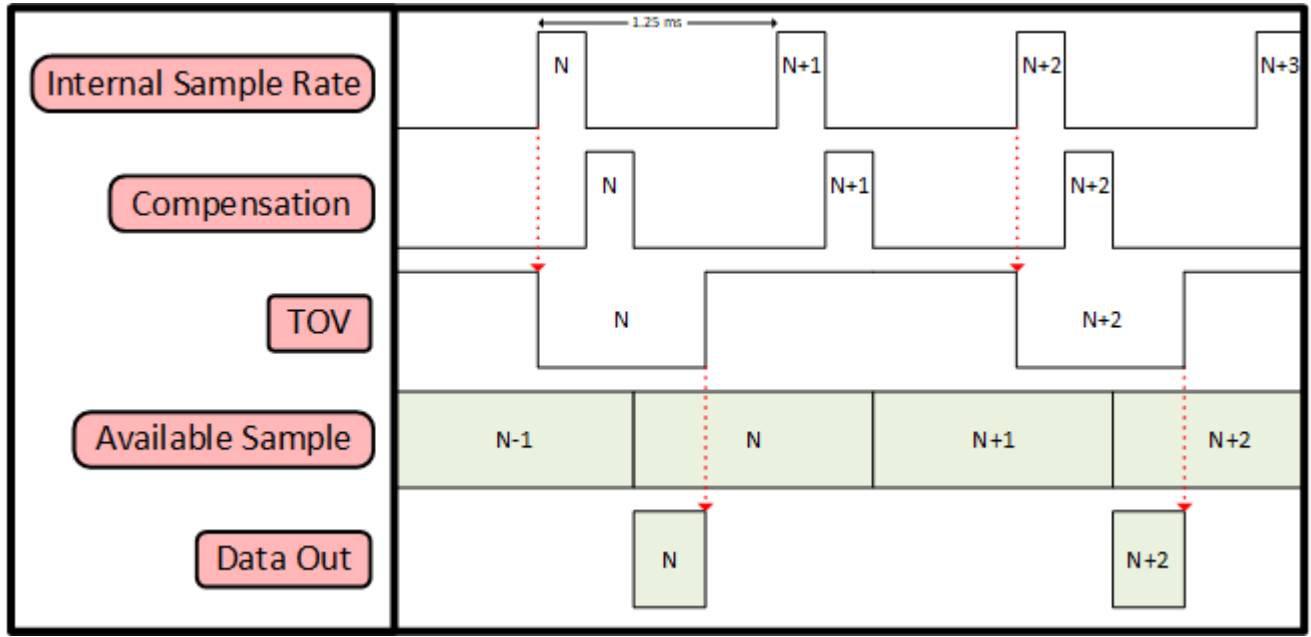

Figure 6 – TOV timing diagram with output sample rate at decimation of 2.

### 4.2.2 External Trigger Input

The *External Trigger (X TRIG)*, pin 8, input provides a means to synchronize the IMU’s sample transmission with an external sampling period. A rising edge signal on the External Trigger input initiates the transmission of the most recent complete sample. When in the External Trigger Mode, the TOV falling edge occurs with the beginning of an internal sample and its rising edge is initiated by the completion of the sample’s compensation. Figure 5 depicts the timing associated with the use of the External Trigger and its relation to the TOV signal.

Please note that the External Trigger Mode must be enabled through the communications protocol for the input to be active, see the protocol section or the MS-CIP specification for details on enabling or disabling the External Trigger.

### 4.2.3 Pulse Per Second Input

The *1 Pulse Per Second Input (1 PPS)*, pin 3, provides a means to synchronize the IMU’s sample transmission with a GPS receiver’s 1 pulse per second output. A Rising Edge signal on the 1 PPS input time initiates a time reset to the nearest second.

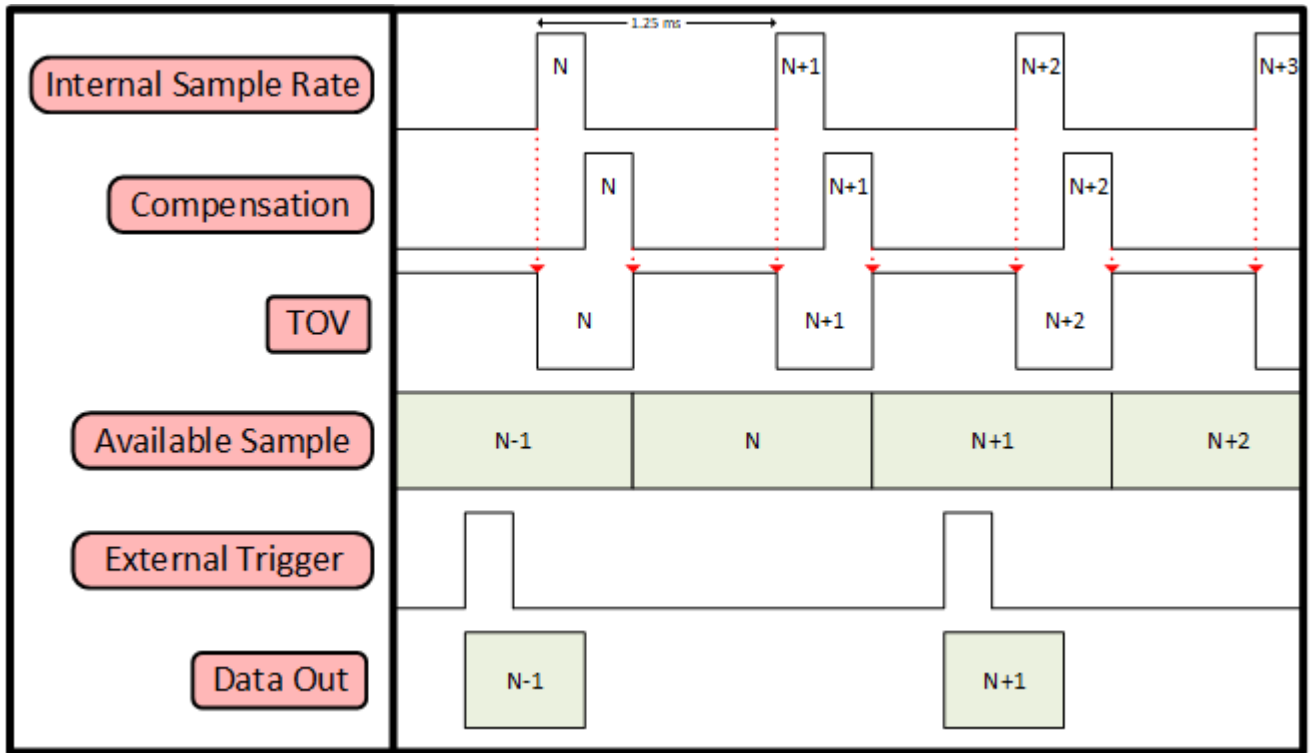

Figure 7 – External Trigger timing diagram.

### 4.3 Internal Sample Rate

The MS-IMU3030 internally samples sensors selected by the configuration at a rate of 800 samples per second. The internal sample rate is used in the output sample rate configuration detailed in the Memsense Communication Interface Protocol.

### 4.4 Communication Interface Protocol

The communication interface protocol is defined in detail in the Memsense Communication Interface Protocol document (MS-CIP DOC00381) which can be found on the MS-IMU3030 product page at [memsense.com](http://memsense.com). The following information provides an overview and contains MS-IMU3030 specific portions of the communication protocol.

The Memsense Communication Interface Protocol (MS CIP) is implemented as a simple architecture to communicate information to and from the measurement device. The protocol is intended to be flexible in allowing customers to configure various features of the device achieving optimized communication modes for various application requirements. Below is a table showing the default output from the MS-IMU3030.

**Table 4 – Default IMU Data Message 0xA2**

BYTE	BYTE NAME	VALUE	DESCRIPTION
0	Sync1	0xA5	First synchronization value used in sample parsing.
1	Sync2	0xA5	Second synchronization value used in sample parsing.
2	Message Type	0xA2	Message type identification code.
3	Payload Size	0x1C	Byte length of the payload.
4	Message Code	0x81	Scaled Acceleration Vector identification code.
5	Data Size	0x0C	Data Size in bytes.
6	X Accel MSB	0x37	X Accel in g. MSB of F32.
7	X Accel Byte 2	0xA7	X Accel in g. Byte 2 of F32.
8	X Accel Byte 1	0xC5	X Accel in g. Byte 1 of F32.
9	X Accel LSB	0xAC	X Accel in g. LSB of F32.
10	Y Accel MSB	0x37	Y Accel in g. MSB of F32.
11	Y Accel Byte 2	0x7B	Y Accel in g. Byte 2 of F32.
12	Y Accel Byte 1	0xA8	Y Accel in g. Byte 1 of F32.
13	Y Accel LSB	0x82	Y Accel in g. LSB of F32.
14	Z Accel MSB	0x3F	Z Accel in g. MSB of F32.
15	Z Accel Byte 2	0x80	Z Accel in g. Byte 2 of F32.
16	Z Accel Byte 1	0x00	Z Accel in g. Byte 1 of F32.
17	Z Accel LSB	0x65	Z Accel in g. LSB of F32.
18	Message Code	0x82	Scaled Angular Rate Vector identification code.
19	Data Size	0x0C	Data Size in bytes.
20	X Gyro MSB	0x37	X Gyro in degrees per second. MSB of F32.
21	X Gyro Byte 2	0xA7	X Gyro in degrees per second. Byte 2 of F32.
22	X Gyro Byte 1	0xC5	X Gyro in degrees per second. Byte 1 of F32.
23	X Gyro LSB	0xAC	X Gyro in degrees per second. LSB of F32.
24	Y Gyro MSB	0x37	Y Gyro in degrees per second. MSB of F32.
25	Y Gyro Byte 2	0x7B	Y Gyro in degrees per second. Byte 2 of F32.
26	Y Gyro Byte 1	0xA8	Y Gyro in degrees per second. Byte 1 of F32.
27	Y Gyro LSB	0x82	Y Gyro in degrees per second. LSB of F32.
28	Z Gyro MSB	0x37	Z Gyro in degrees per second. MSB of F32.
29	Z Gyro Byte 2	0x49	Z Gyro in degrees per second. Byte 2 of F32.
30	Z Gyro Byte 1	0x53	Z Gyro in degrees per second. Byte 1 of F32.
31	Z Gyro LSB	0x9C	Z Gyro in degrees per second. LSB of F32.
32	Checksum 1	0x0C	Fletcher-16 checksum block 1 MSB
33	Checksum 2	0x23	Fletcher-16 checksum block 2 LSB
Resulting Complete Command			

A5A5A21C810C37A7C5AC377BA8823F800065820C37A7C5AC377BA8823749539C0C23

#### 4.4.1 IMU Sample Rate Configure 0x0204

The *IMU Sample Rate Configure* provides a means to configure and save the rate at which all IMU data messages are transmitted. *IMU Message Config* is used to control individual measurements.

The *IMU Sample Rate Configure* function codes define the function to be performed on the device's inertial measurements. The associated codes and functions are listed in Table 5 below.

**Table 5 – IMU Sample Rate Function Codes**

CODE	IMU SAMPLE RATE FUNCTION
0X01	Use new settings.
0x02	Request current settings.
0x03	Save current settings as startup settings.
0x04	Load saved startup settings.
0x05	Reset to default settings.

A 16-bit decimation value must be provided and is used to divide the internal sample rate to the desired output sample rate. The MS-IMU3030 has an internal sample rate of 800Hz therefore providing a decimation value of 0x0008 (8 decimal) configures the output sample rate to 100Hz.

See the MS-CIP at [memsense.com](http://memsense.com) under the MS-IMU3030 product page for more details regarding IMU Sample Rate Configure.

#### 4.4.2 Configure Filter 0x0203

The *Configure Filter* message provides a means for configuring and saving internal digital filtering options. The *Filter Function* allows the configuration to be used, queried, saved, loaded from startup settings, and reset to defaults. Table 6 details the associated codes and functions.

**Table 6 –Filter Function Codes**

CODE	FILTER FUNCTION
0X01	Use new settings.
0x02	Request current settings.
0x03	Save current settings as startup settings.
0x04	Load saved startup settings.
0x05	Reset to default settings.

The *Filter Control* codes allow filtering to be disabled or enabled in Infinite Impulse Response (IIR) mode. Care in selecting a filter bandwidth value that supports the Nyquist Sampling Theorem is suggested. The filter cutoff options listed here are specific to the MS-IMU3030. Filter cutoff options for the MS-IMU3030 are listed in Table 7.

**Table 7 – Filter Bandwidth Control Codes**

CODE	FILTER CONTROL CODES
0x00	Disable Filter
0x01	IIR Filter -3 dB at 25Hz
0x02	IIR Filter -3 dB at 50Hz (Default)
0x03	IIR Filter -3 dB at 75Hz
0x04	IIR Filter -3 dB at 100Hz
0x05	IIR Filter -3 dB at 10Hz
0x06	IIR Filter -3 dB at 150Hz
0x07	IIR Filter -3 dB at 200Hz

#### 4.4.3 Select Sensors 0x0205

The *Select Sensors* message provides a means to configure and save the contents of the IMU data messages transmitted.

The *Select Sensors* function codes define the function to be performed on the device's message format. The associated codes and functions for the MS-IMU3030 are listed in Table 8 below.

**Table 8 – Select Sensors Function Codes**

CODE	SELECT SENSORS FUNCTION
0x01	Use new settings.
0x02	Request current settings.
0x03	Save current settings as startup settings.
0x04	Load saved startup settings.
0x05	Reset to default settings.

Table 9 lists the codes for the available measurements to be selected.

**Table 9 – Select Sensors Options**

CODE	SELECT SENSORS OPTIONS
0x81	Scaled Acceleration Vector in g
0x82	Scaled Angular Rate Vector in deg/sec
0x83	Scaled Magnetic Field Vector in gauss
0x84	Delta Theta Vector in Radians
0x85	Delta Velocity Vector in m/s
0x87	Scaled Temperature in Celsius
0x88	GPS Correlated Time

For each measurement selected the associated data code must be provided. When a Select Sensor message requests a sensor option that doesn't exist in the IMU (magnetometer or pressure), a NACK message will be returned.

*See the MS-CIP at [memsense.com](http://memsense.com) under the MS-IMU3030 product page for more details regarding Select Sensors.*

#### 4.4.4 Config Accel Range 0x0207

The MS-IMU3030 supports the configuration of accelerometer dynamic ranges. The following configuration information details the options available and associated codes used in the communication protocol.

The *Config Accel Range* message provides a means for configuring and saving the triaxial accelerometer dynamic range options.

The *Config Accel Range Function* allows the configuration to be used, queried, saved, loaded from startup settings, and reset to defaults. Table 10 details the associated codes and functions.

**Table 10 –Config Accel Range Function Codes**

CODE	CONFIGURE ACCEL RANGE FUNCTION CODES
0X01	Use new settings.
0x02	Request current settings.
0x03	Save current settings as startup settings.
0x04	Load saved startup settings.
0x05	Reset to default settings.

The *Accel Range* codes allow the dynamic range of the accelerometer to be changed to one of the 3 supported ranges and effect all three axes of the sensor. The options for the accelerometer dynamic range are controlled in the *Accel Range Codes* listed in Table 11.

**Table 11 – Accel Range Codes**

CODE	ACCEL RANGE CODES	IMU MODEL NUMBER
0x00	Accelerometer range $\pm 2 g$	MS-IMU3030M
		MS-IMU3030
		MS-IMU3030MH
		MS-IMU3030H
0x01	Accelerometer range $\pm 4 g$	MS-IMU3030M
		MS-IMU3030
		MS-IMU3030MH
		MS-IMU3030H
0x02	Accelerometer range $\pm 8 g$	MS-IMU3030M
		MS-IMU3030
		MS-IMU3030MH
		MS-IMU3030H
0x03	Accelerometer range $\pm 10 g$	MS-IMU3030ME
		MS-IMU3030E
		MS-IMU3030MHH
		MS-IMU3030HH
0x05	Accelerometer range $\pm 20 g$	MS-IMU3030ME
		MS-IMU3030E
		MS-IMU3030MHH
		MS-IMU3030HH
0x06	Accelerometer range $\pm 40 g$	MS-IMU3030ME
		MS-IMU3030E
		MS-IMU3030MHH
		MS-IMU3030HH

#### 4.4.5 Config Gyro Range 0x0208

The MS-IMU3030 supports the configuration of gyroscope dynamic ranges. The following configuration information details the options available and associated codes used in the communication protocol.

The *Config Gyro Range* message provides a means for configuring and saving the triaxial gyroscope dynamic range options. The *Config Gyro Range Function* allows the configuration to be used, queried, saved, loaded from startup settings, and reset to defaults. Table 12 details the associated codes and functions.

**Table 12 – Config Gyro Range Function Codes**

CODE	CONFIGURE GYRO RANGE FUNCTION CODES
0x01	Use new settings.
0x02	Request current settings.
0x03	Save current settings as startup settings.
0x04	Load saved startup settings.
0x05	Reset to default settings.

The *Gyro Range* codes allow the dynamic range of the gyroscope to be changed to 1 of the 5 supported ranges and effect all 3 axes of the sensor. The options for the gyroscope dynamic range are controlled in the *Gyro Range Codes*. The MS-IMU3030 codes are listed in Table 13.

**Table 13 – MS-IMU3030 Gyro Range Codes**

CODE	GYRO RANGE CODES
0x06	Gyroscope range $\pm 75$ °/s
0x07	Gyroscope range $\pm 200$ °/s
0x03	Gyroscope range $\pm 480$ °/s (Default)
0x04	Gyroscope range $\pm 960$ °/s
0x05	Gyroscope range $\pm 1920$ °/s

**5.0 OPTIONS**

**5.1 Part Numbering**

The standard part numbers, sensor ranges and associated ECCNs for the MS-IMU3030 are listed in the table below. MS-IMU3030 models with part numbers from MP00066-001 to MP00067-006 are classified by ECCN for export. The remaining model numbers have yet to be classified. When purchasing an export-controlled model please contact sales for an End User Form.

**Table 14 – Standard part numbers**

Model Number	Part Number	Accel (g)	Rate (°/s)	Mag (gauss)	ECCNs
MS-IMU3030M	MP00066-001	±2, ±4, or ±8	±75, ±200, ±480, ±960, or ±1920	±2	7A003
MS-IMU3030	MP00066-002	±2, ±4, or ±8	±75, ±200, ±480, ±960, or ±1920	None	7A003
MS-IMU3030ME	MP00066-003	±10, ±20, or ±40	±75, ±200, or ±480	±2	7A994
MS-IMU3030E	MP00066-004	±10, ±20, or ±40	±75, ±200, or ±480	None	7A994
MS-IMU3030MHH	MP00066-007	±10, ±20, or ±40	±75, ±200, ±480, ±960, or ±1920	±2	7A003
MS-IMU3030HH	MP00066-008	±10, ±20, or ±40	±75, ±200, ±480, ±960, or ±1920	None	7A003
MS-IMU3030R*	MP00066-102	±2, ±4, or ±8	±75, ±200, ±480, ±960, or ±1920	None	7A003

\*ROHS Version of the MP00066-002

**5.2 IMU Accessories**

Accessories available for the MS-IMU3030 include interface cables, a USB data acquisition module (USB-DAQ) and the MS-IMU3030 configuration software. The accessories allow an end user to rapidly connect, configure and collect evaluation data with the MS-IMU3030. The software provides valuable tools used in developing communications with the IMU. The table below provides the accessory part number details.

**Table 15 – Accessories part numbers**

Model Number	Part Number	Description
C30X0-G10F-H6F-36	MP00063-001	IMU 36-inch Development Interface Cable
C30X0-G10F-PTL-08	MP00063-003	IMU 8-inch Unterminated Interface Cable
C30X0-G10F-PTL-12	MP00063-004	IMU 12-inch Unterminated Interface Cable
USB-DAQ	MP00082-101	USB IMU Data Interface Module, 36"
MS-CIP-EVAL	N/A	IMU Configuration Software

### 5.3 IMU Development Kit

Development kits available for the MS-IMU3030 are listed in Table 16 below.

**Table 16 – Development Kit**

Dev Kit Part Number	#	Part Number	Content Description
MP00087-001	1	CM01614	USB 2.0 A to Micro-USB B Cable 3FT
	2	CM01667	Box, Memsense Development Kit
	3	MP00063-018	Cable 36IN Gecko (F) to Gecko (F)
	4	MP00063-019	Cable 36IN Gecko (M) to Gecko (F)
	5	MP00069-001	USB Drive MS-CIP Evaluation Application and User Manual
	6	MP00082-101	USB IMU Data Interface Module, 36"
	7	MP00083-101	IMU Breakout Development Board
	8	MP00084-101	USB IMU Data Interface Module External Power Adapter
	9	MP00085-001	USB-DAQ External Power Cable

### 5.4 IMU Evaluation Kit

Evaluation Kits available for the MS-IMU3030 are listed in Table 17 below.

**Table 17 – Evaluation Kit**

Eval Kit Part Number	#	Part Number	Content Description
MP00088-001	1	CM01667	Box, Memsense Development Kit
	2	MP00063-019	Cable 36IN Gecko (M) to Gecko (F)
	3	MP00069-001	USB Drive MS-CIP Evaluation Application and User Manual
	4	MP00082-101	USB IMU Data Interface Module, 36"
	5	MP00084-101	USB IMU Data Interface Module External Power Adapter
	6	MP00085-001	USB-DAQ External Power Cable